

635

KITY
MACHINES A BOIS

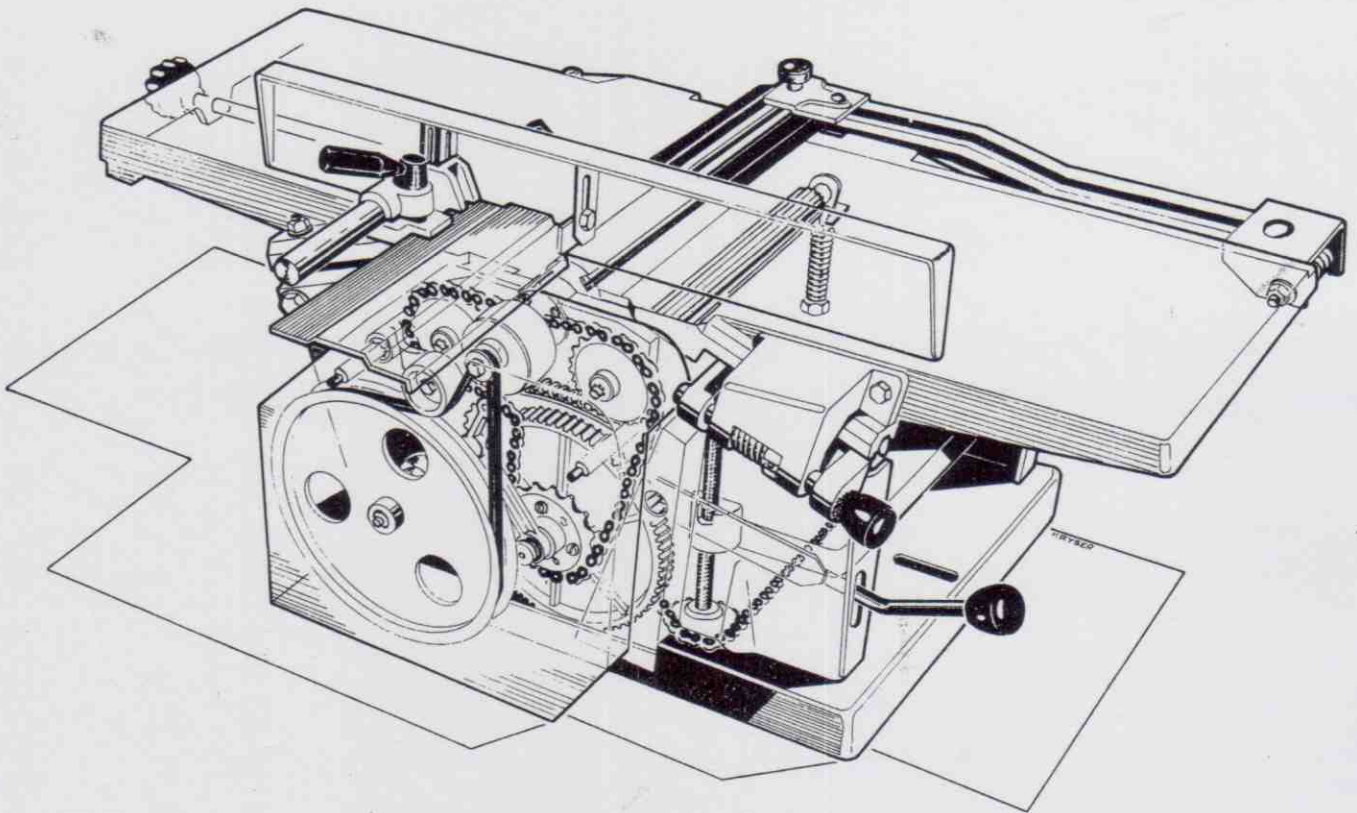

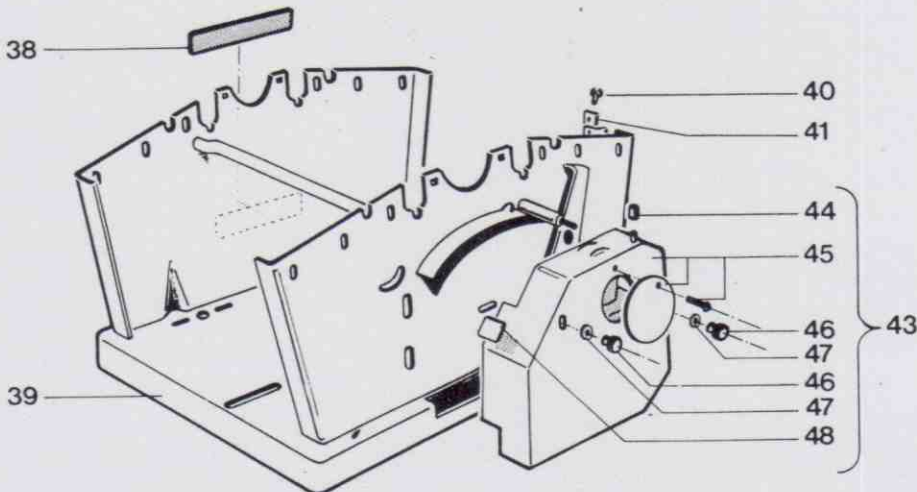
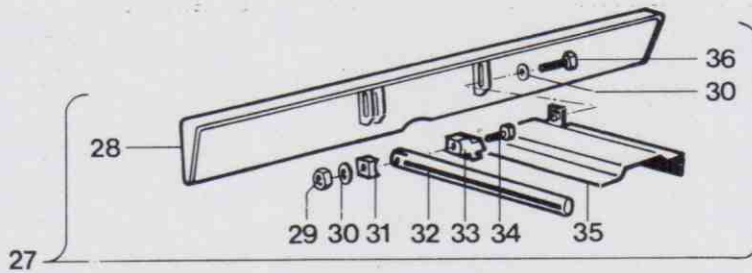
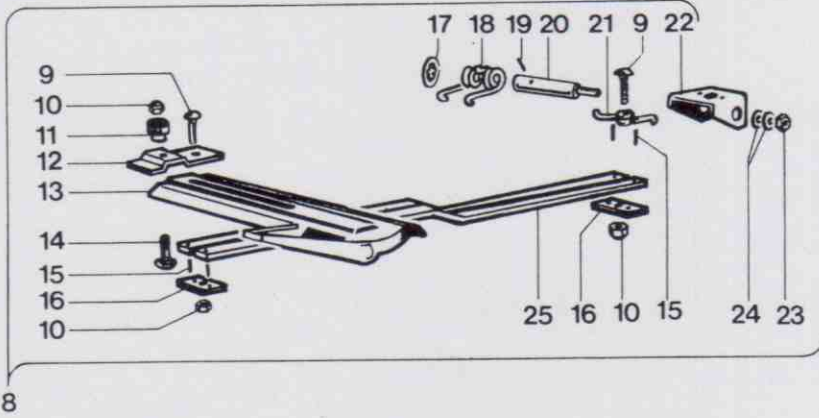
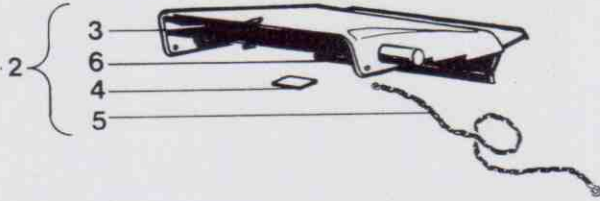

N.	REF.	Q.	PR.
1			
2		1	30,34
3		1	27,48
4		1	0,05
5	1402	1	2,24
6	516	1	0,57
7			
8		1	38,87
9	92503	2	0,15
10	90301	3	0,15
11	1362	1	0,70
12	1310	1	0,98
13	1308	1	18,79
14	92501	1	0,15
15	95505	4	0,10
16	1357	2	0,36
17	95207	1	0,10
18	1361	1	0,51
19	95415	1	0,10
20	1363	1	2,44
21	1360	1	0,22
22	1364	1	1,35
23	90713	1	0,10
24	94117	2	0,10
25	1306	2	5,68
26			
27		1	45,31
28	2100	1	22,12
29	90713	1	0,10
30	94117	2	0,10
31	851	1	0,60
32	849	1	8,85
33	1480	1	7,07
34	92872	1	0,23
35	1478	1	5,99
36	92851	1	0,15
37			
38		1	0,31
39		1	125,10
40	92104	2	0,10
41	1354	1	0,35
42			
43		1	26,40
44	2040	1	0,26
45		1	24,97
46	2233	2	0,46
47	94105	2	0,10
48	1656	1	0,05
49			
50			
51			
52			
53			
54			
55			

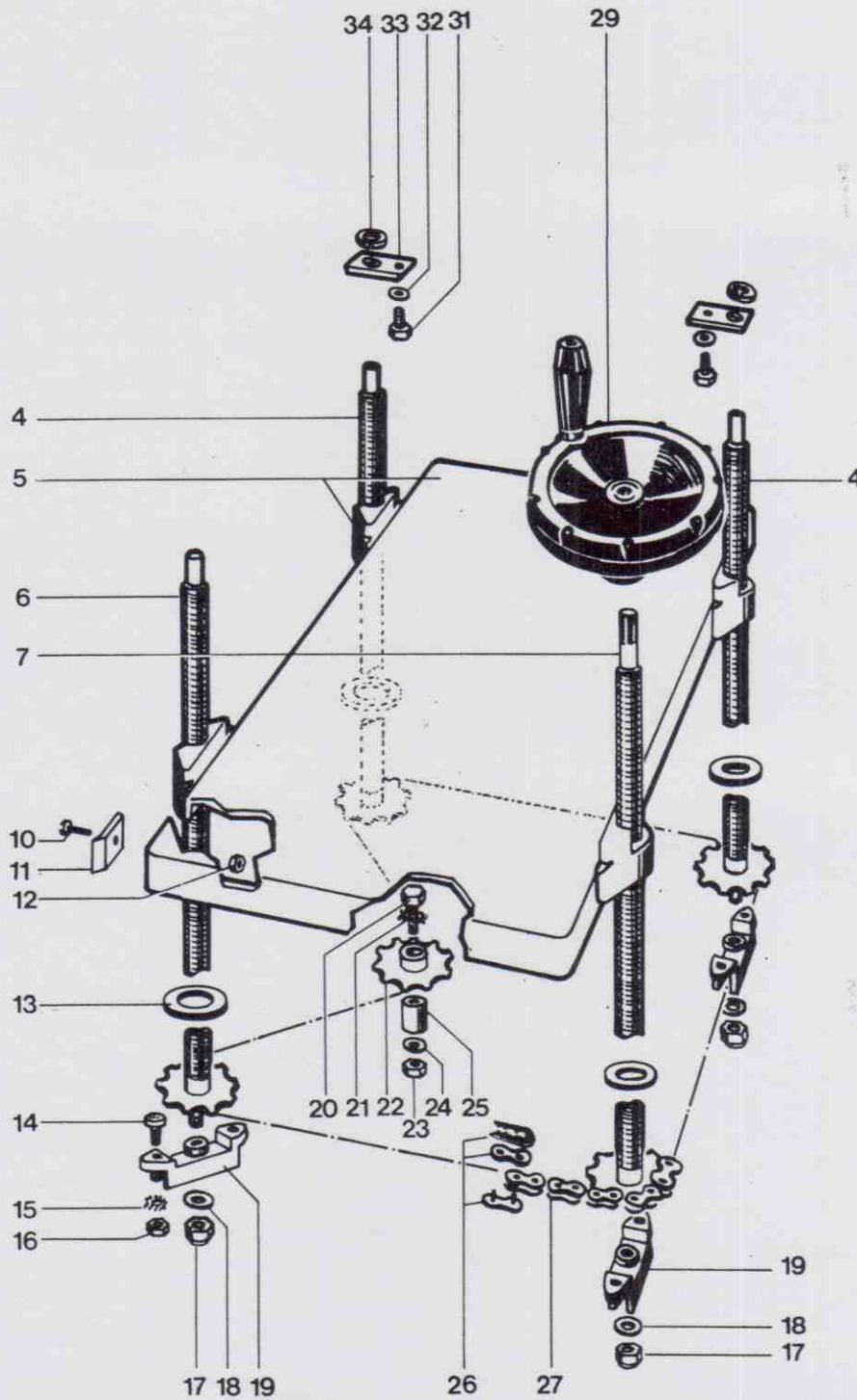

N.	REF.	Q.	PR.
1			
2			
3			
4		2	9,20
5		1	84,71
6		1	6,92
7		1	10,81
8			
9			
10	92104	1	0,10
11	2158	1	0,59
12	90701	1	0,10
13	1435	4	0,49
14	92201	8	0,15
15	94403	8	0,10
16	90709	8	0,10
17	90305	4	0,23
18	94117	4	0,10
19	510	4	5,20
20	92863	1	0,15
21	94405	1	0,10
22		1	1,38
23	90713	1	0,10
24	94119	1	0,10
25	96408	1	0,55
26		1	0,40
27		1	2,56
28			
29		1	15,21
30			
31	92819	2	0,10
32	94105	2	0,10
33	1357	2	0,36
34		2	0,22
35			
36			
37			
38			
39			
40			
41			
42			
43			
44			
45			
46			
47			
48			
49			
50			
51			
52			
53			
54			
55			

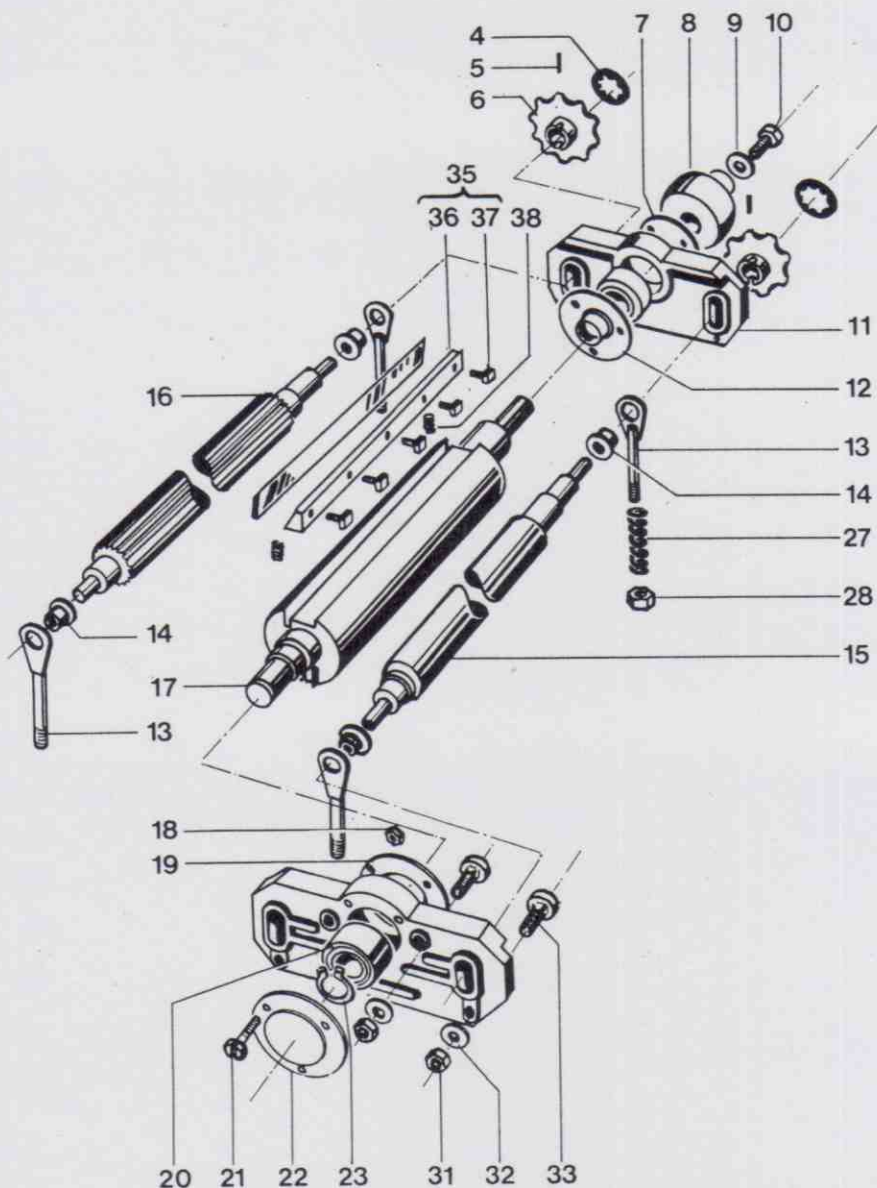

N.	REF.	Q.	PR.
1			
2			
3			
4	95205	2	0,10
5	95415	2	0,10
6		2	2,80
7	385	1	0,57
8	524	1	14,41
9	94109	1	0,10
10	92819	1	0,10
11	506	2	16,86
12	386	1	0,57
13		4	0,70
14	96418	4	0,80
15	507	1	19,32
16	508	1	31,50
17	808	1	155,68
18	90701	6	0,10
19	387	1	0,57
20	96509	2	7,30
21	92108	6	0,10
22	388	1	0,57
23	95101	1	0,10
24			
25			
26			
27	887	4	0,10
28	90709	4	0,10
29			
30			
31	90709	8	0,10
32	94105	8	0,10
33	92201	8	0,15
34			
35		2	11,93
36	809	2	10,93
37	831	8	0,25
38	832	4	0,10
39			
40			
41			
42			
43			
44			
45			
46			
47			
48			
49			
50			
51			
52			
53			
54			
55			

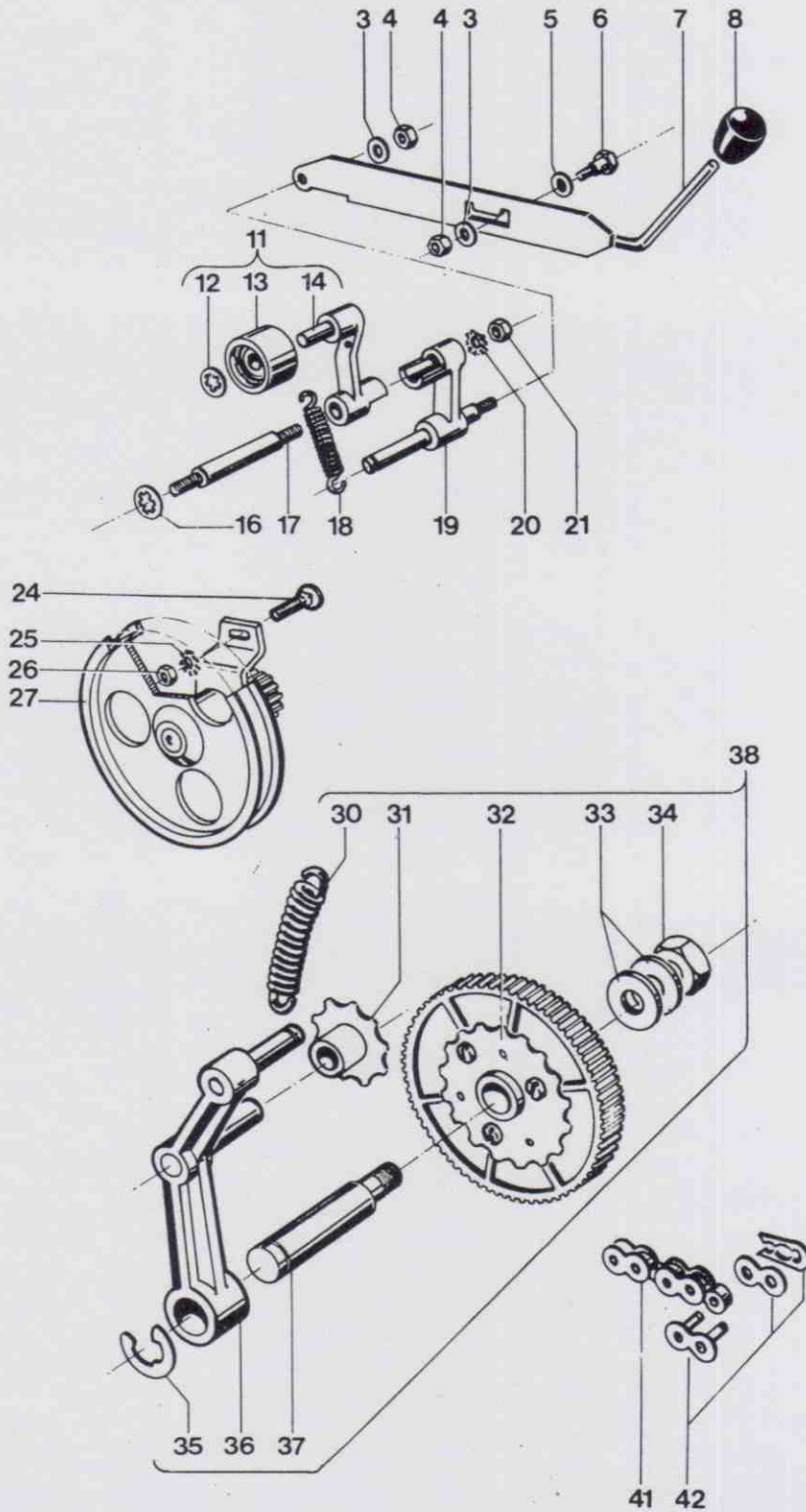

N.	REF.	Q.	PR.
1			
2			
3	94105	2	0,10
4	90709	2	0,10
5	94117	1	0,10
6	545	1	0,28
7	544	1	4,78
8	96301	1	1,29
9			
10			
11		1	18,37
12	95205	1	0,10
13	509	1	8,87
14		1	8,56
15			
16	95207	1	0,10
17	539	1	1,49
18	269	1	0,20
19		1	8,52
20	94405	1	0,10
21	90713	1	0,10
22			
23			
24	92201	2	0,15
25	94403	2	0,10
26	90709	2	0,10
27	511	1	45,35
28			
29			
30	269	1	0,20
31		1	2,21
32	1009	1	12,98
33	94133	2	0,23
34	90717	1	0,15
35	95310	1	0,10
36		1	7,86
37	522	1	1,37
38		1	26,99
39			
40			
41		1	1,52
42		1	0,40
43			
44			
45			
46			
47			
48			
49			
50			
51			
52			
53			
54			
55			

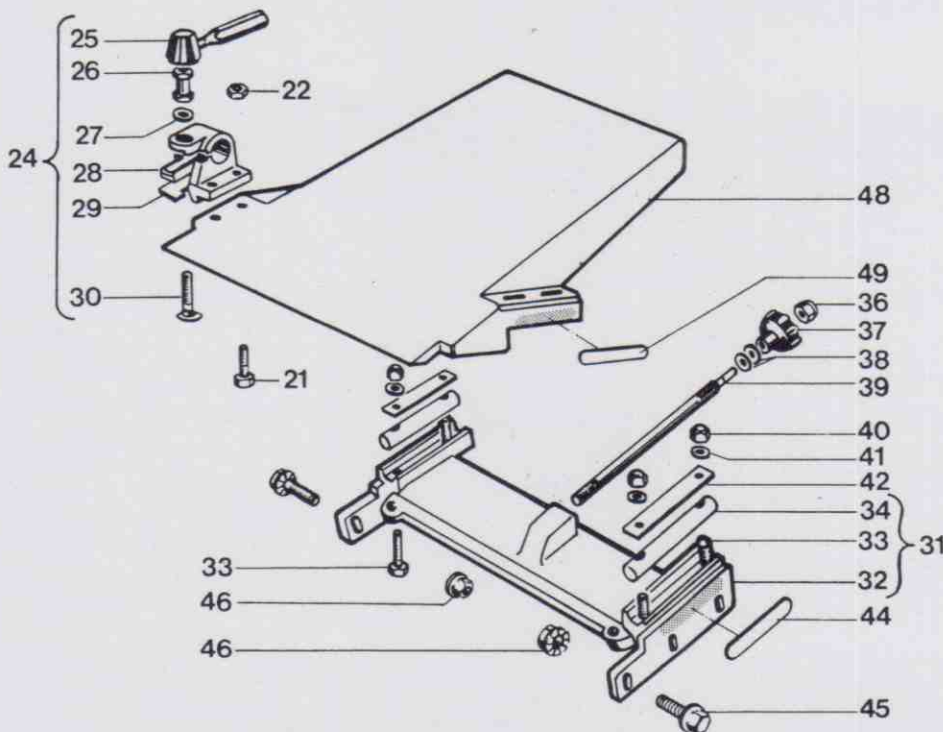
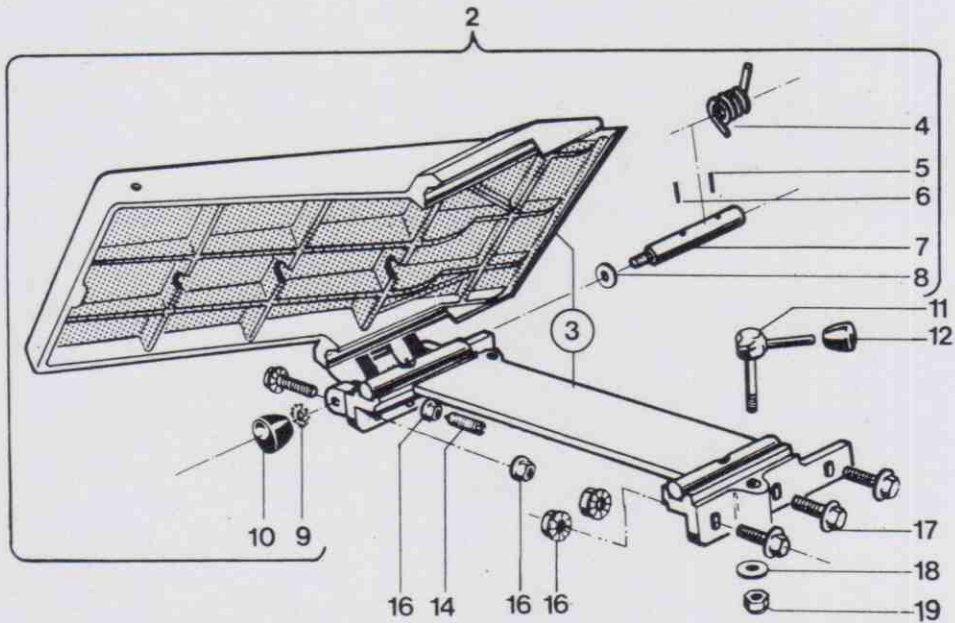

N.	REF.	Q.	PR.
1			
2		1	151,00
3		1	144,88
4	1486	1	0,25
5	95410	1	0,10
6	95401	1	0,10
7	533	1	3,50
8	94141	1	0,10
9	94405	1	0,10
10	96305	1	1,97
11		1	10,62
12	96303	1	1,19
13			
14	91405	1	0,70
15			
16	90201	7	0,15
17	91601	5	0,23
18	94117	1	0,10
19	90305	1	0,23
20			
21	92203	2	0,15
22	90709	2	0,10
23			
24		1	20,39
25	2248	1	5,13
26	2249	1	0,67
27	94117	1	0,10
28	1479	1	12,85
29	1481	1	0,40
30	92525	1	0,40
31		1	38,14
32	1106	1	31,70
33	92846	4	0,10
34	1062	2	2,46
35			
36	90305	1	0,23
37	584	1	4,81
38	94125	2	0,10
39	1299	1	5,18
40	90301	4	0,15
41	94801	4	0,10
42	1108	2	0,39
43			
44	1346	1	0,16
45	91601	6	0,23
46	90201	6	0,15
47			
48	1421	1	74,90
49	1345	1	0,16
50			
51			
52			
53			
54			
55			